



1.8V, Resistor-Programmable TEMPERATURE SWITCH and ANALOG OUT TEMPERATURE SENSOR in SC70

FEATURES

- **ACCURACY:** $\pm 1^{\circ}\text{C}$ (typical at $+25^{\circ}\text{C}$)
- **PROGRAMMABLE TRIP POINT**
- **PROGRAMMABLE HYSTERESIS:** $5^{\circ}\text{C}/10^{\circ}\text{C}$
- **OPEN-DRAIN OUTPUTS**
- **LOW-POWER:** $110\mu\text{A}$ (max)
- **WIDE VOLTAGE RANGE:** $+1.8\text{V}$ to $+18\text{V}$
- **OPERATION:** -40°C to $+150^{\circ}\text{C}$
- **ANALOG OUT:** $10\text{mV}/^{\circ}\text{C}$
- **SC70-6 AND SOT23-6 PACKAGES**

APPLICATIONS

- **POWER-SUPPLY SYSTEMS**
- **DC-DC MODULES**
- **THERMAL MONITORING**
- **ELECTRONIC PROTECTION SYSTEMS**

DESCRIPTION

The TMP300 is a low-power, resistor-programmable, digital output temperature switch. It allows a threshold point to be set by adding an external resistor. Two levels of hysteresis are available. The TMP300 has a V_{TEMP} analog output that can be used as a testing point or in temperature-compensation loops.

The TMP300 detects temperature with $\pm 4^{\circ}\text{C}$ accuracy (max) over -40°C to $+125^{\circ}\text{C}$.

With a supply voltage as low as 1.8V and low current consumption, the TMP300 is ideal for power-sensitive systems.

Available in two micropackages that have proven thermal characteristics, this part gives a complete and simple solution for users who need simple and reliable thermal management.

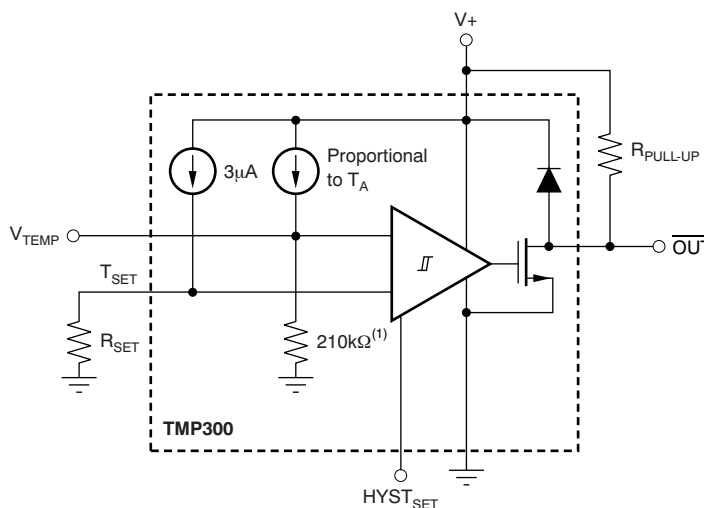
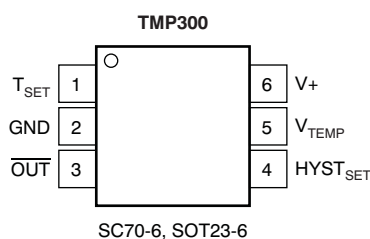

NOTE: (1) Thinfilm resistor with approximately 10% accuracy; however, this accuracy error is trimmed out at the factory.



Please be aware that an important notice concerning availability, standard warranty, and use in critical applications of Texas Instruments semiconductor products and disclaimers thereto appears at the end of this data sheet.

All trademarks are the property of their respective owners.



This integrated circuit can be damaged by ESD. Texas Instruments recommends that all integrated circuits be handled with appropriate precautions. Failure to observe proper handling and installation procedures can cause damage.

ESD damage can range from subtle performance degradation to complete device failure. Precision integrated circuits may be more susceptible to damage because very small parametric changes could cause the device not to meet its published specifications.

ORDERING INFORMATION⁽¹⁾

PRODUCT	PACKAGE-LEAD	PACKAGE DESIGNATOR	PACKAGE MARKING
TMP300	SC70-6	DCK	BPN
TMP300	SOT23-6	DBV	T300

(1) For the most current package and ordering information see the Package Option Addendum at the end of this document, or see the TI web site at www.ti.com.

ABSOLUTE MAXIMUM RATINGS⁽¹⁾

		VALUE	UNIT
Supply Voltage	V+	+18	V
Signal Input Terminals, Voltage ⁽²⁾		-0.5 to (V+) + 0.5	V
Signal Input Terminals, Current ⁽²⁾		±10	mA
Output Short-Circuit ⁽³⁾	I _{sc}	Continuous	
Open-Drain Output		(V+) + 0.5	V
Operating Temperature	T _A	-40 to +150	°C
Storage Temperature	T _A	-55 to +150	°C
Junction Temperature	T _J	+150	°C
ESD Rating	Human Body Model (HBM)	4000	V
	Charged Device Model (CDM)	1000	V

- (1) Stresses above these ratings may cause permanent damage. Exposure to absolute maximum conditions for extended periods may degrade device reliability. These are stress ratings only, and functional operation of the device at these or any other conditions beyond those specified is not supported.
- (2) Input terminals are diode-clamped to the power-supply rails. Input signals that can swing more than 0.5V beyond the supply rails should be current limited to 10mA or less.
- (3) Short-circuit to ground.

ELECTRICAL CHARACTERISTICS

 At $V_S = 3.3V$ and $T_A = -40^\circ C$ to $+125^\circ C$, unless otherwise noted.

PARAMETER	TEST CONDITIONS	TMP300			UNIT
		MIN ⁽¹⁾	TYP ⁽¹⁾	MAX ⁽¹⁾	
TEMPERATURE MEASUREMENT					
Measurement Range	$V_S = 2.35V$ to $18V$	-40		+125	$^\circ C$
	$V_S = 1.8V$ to $2.35V$	-40		$100(V_S - 0.95)$	$^\circ C$
TRIP POINT					
Total Accuracy	$T_A = -40^\circ C$ to $+125^\circ C$		± 2	± 4	$^\circ C$
R_{SET} Equation	T_C is in $^\circ C$		$R_{SET} = 10(50 + T_C)/3$		$k\Omega$
HYSTERESIS SET INPUT					
LOW Threshold				0.4	V
HIGH Threshold		$V_S - 0.4$			V
Threshold Hysteresis	$HYST_{SET} = GND$		5		$^\circ C$
	$HYST_{SET} = V_S$		10		$^\circ C$
DIGITAL OUTPUT					
Logic Family			CMOS		
Open-Drain Leakage Current	$OUT = V_S$			10	μA
Logic Levels					
V_{OL}	$V_S = 1.8V$ to $18V$, $I_{SINK} = 5mA$			0.3	V
ANALOG OUTPUT					
Accuracy			± 2	± 3	$^\circ C$
Temperature Sensitivity			10		$mV/^\circ C$
Output Voltage	$T_A = +25^\circ C$	720	750	780	mV
V_{TEMP} Pin Output Resistance			210		$k\Omega$
POWER SUPPLY					
Quiescent Current ⁽²⁾	I_Q , $V_S = 1.8V$ to $18V$, $T_A = -40^\circ C$ to $+125^\circ C$			110	μA
TEMPERATURE RANGE					
Specified Range	T_A	$V_S = 2.35V$ to $18V$	-40	+125	$^\circ C$
		$V_S = 1.8V$ to $2.35V$	-40	$100(V_S - 0.95)$	$^\circ C$
Operating Range	T_A	$V_S = 2.35V$ to $18V$	-40	+150	$^\circ C$
		$V_S = 1.8V$ to $2.35V$	-50	$100(V_S - 0.95)$	$^\circ C$
Thermal Resistance	θ_{JA}				
SC70				250	$^\circ C/W$
SOT23-6				180	$^\circ C/W$

 (1) 100% of production is tested at $T_A = +85^\circ C$. Specifications over temperature range are ensured by design.

 (2) See [Figure 1](#) for typical quiescent current.

TYPICAL CHARACTERISTICS

At $V_S = 5V$, unless otherwise noted.

QUIESCENT CURRENT OVER TEMPERATURE AND SUPPLY

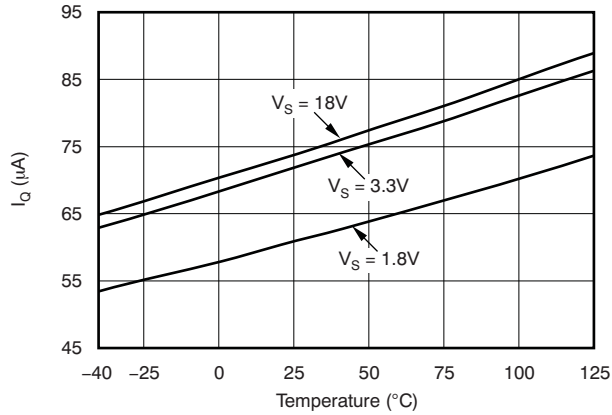

Figure 1.

R_{SET} SHIFT DUE TO R_{SET} TOLERANCE

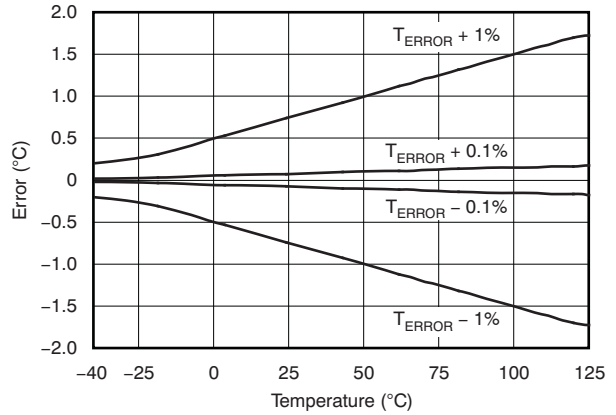

Figure 2.

R_{SET} vs TEMPERATURE

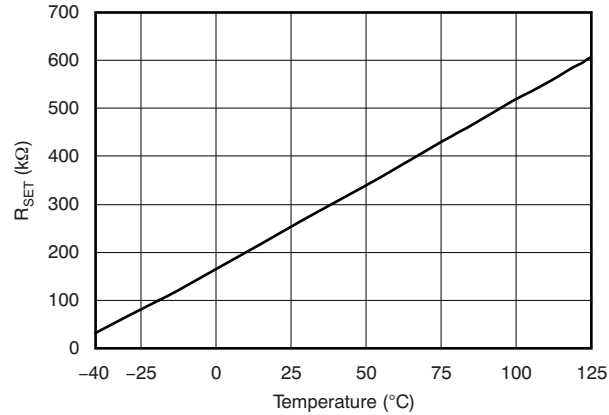

Figure 3.

TYPICAL TRIP ERROR

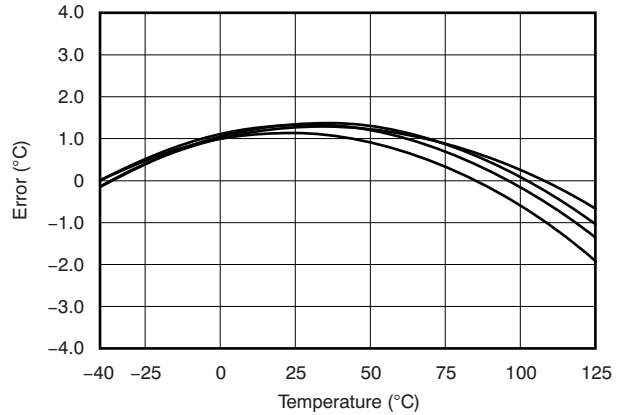

Figure 4.

TYPICAL ANALOG OUTPUT ERROR

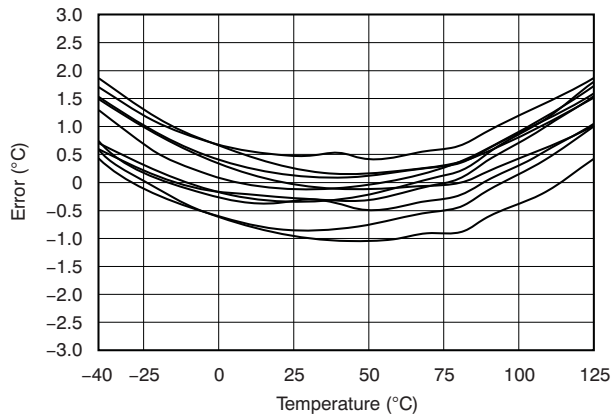

Figure 5.

ANALOG PSR OVER TEMPERATURE

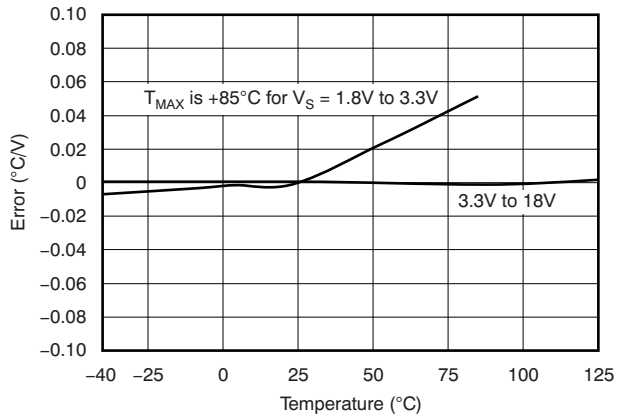
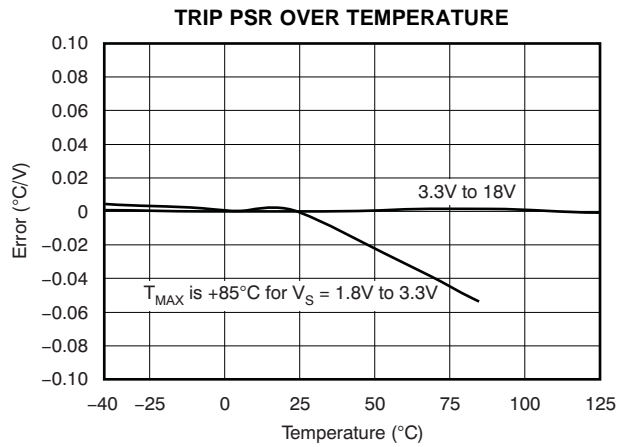

Figure 6.

TYPICAL CHARACTERISTICS (continued)

At $V_S = 5V$, unless otherwise noted.



APPLICATIONS INFORMATION

The TMP300 is a thermal sensor designed for over-temperature protection circuits in electronic systems. The TMP300 uses a set resistor to program the trip temperature of the digital output. An additional high-impedance (210kΩ) analog voltage output provides the temperature reading.

CALCULATING R_{SET}

The set resistor (R_{SET}) provides a threshold voltage for the comparator input. The TMP300 trips when the V_{TEMP} pin exceeds the T_{SET} voltage. The value of the set resistor is determined by the analog output function and the 3μA internal bias current.

To set the TMP300 to trip at a preset value, calculate the R_{SET} resistor value according to Equation 1 or Equation 2:

$$R_{SET} = \frac{(T_{SET} \times 0.01 + 0.5)}{3e^{-6}} \tag{1}$$

Where T_{SET} is in °C; or

$$R_{SET} \text{ in } k\Omega = \frac{10(50 + T_{SET})}{3} \tag{2}$$

Where T_{SET} is in °C.

USING V_{TEMP} TO TRIP THE DIGITAL OUTPUT

The analog voltage output can also serve as a voltage input that forces a trip of the digital output to simulate a thermal event. This simulation facilitates easy system design and test of thermal safety circuits, as shown in Figure 8.

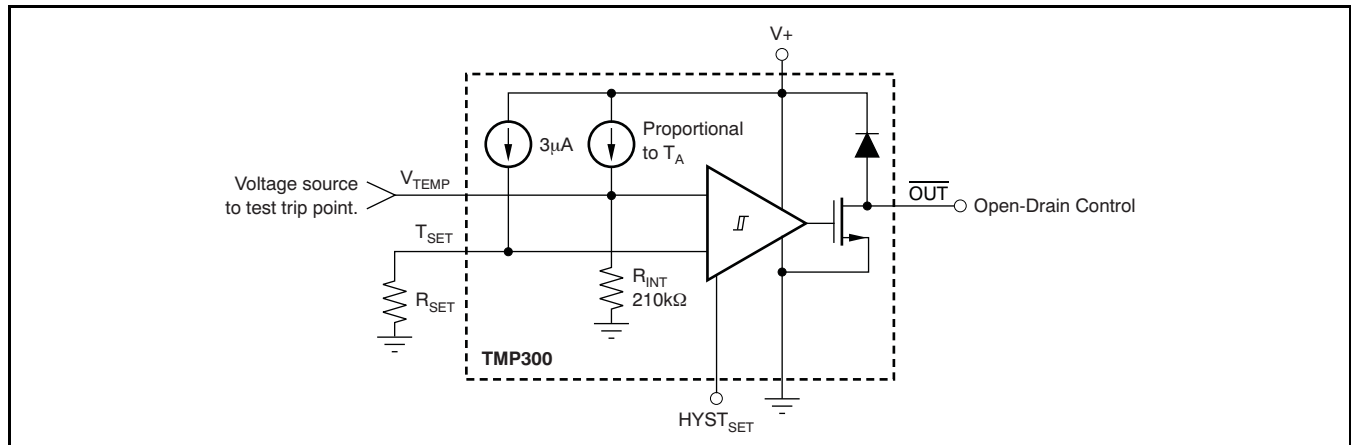

Figure 8. Applying Voltage to Trip Digital Output

ANALOG TEMPERATURE OUTPUT

The analog out or V_{TEMP} pin is high-impedance (210k Ω). Avoid loading this pin to prevent degrading the analog out value or trip point. Buffer the output of this pin when using it for direct thermal measurement. Figure 9 shows buffering of the analog output signal.

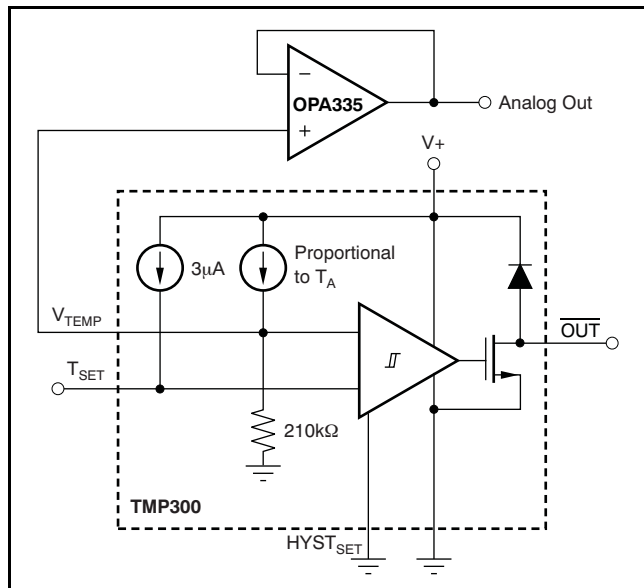

Figure 9. Buffering the Analog Output Signal

USING A DAC TO SET THE TRIP POINT

The trip point is easily converted by changing the digital-to-analog converter (DAC) code. This technique can be useful for control loops where a large thermal mass is being brought up to the set temperature and the \overline{OUT} pin is used to control the heating element. The analog pin can be monitored in a control algorithm that adjusts the set temperature to prevent overshoot. Trip set voltage error versus temperature is shown in Figure 10, which shows error in $^{\circ}\text{C}$ of the comparator input over temperature. An alternative method of setting the trip point by using a DAC is shown in Figure 11.

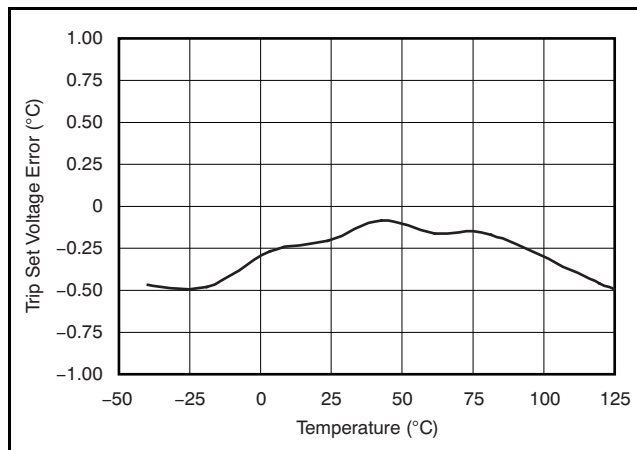

Figure 10. Trip Set Voltage Error vs Temperature

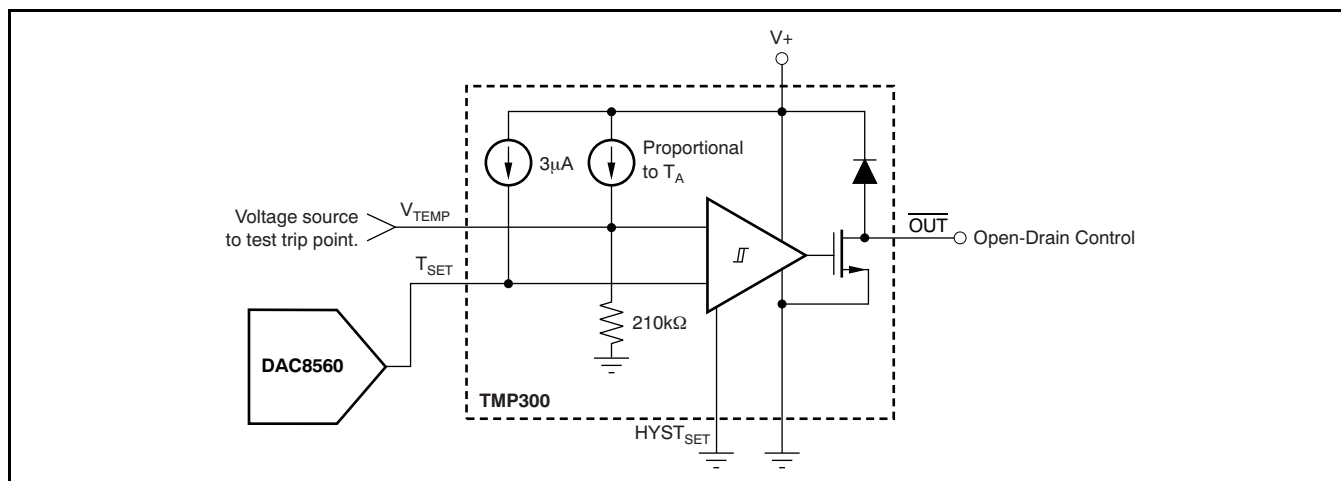

Figure 11. DAC Generates the Voltage-Driving T_{SET} Pin

HYSTERESIS

The hysteresis pin has two settings. Grounding HYST_{SET} results in 5°C of hysteresis. Connecting it to V_S results in 10°C of hysteresis. Hysteresis error variation over temperature is shown in Figure 12 and Figure 13.

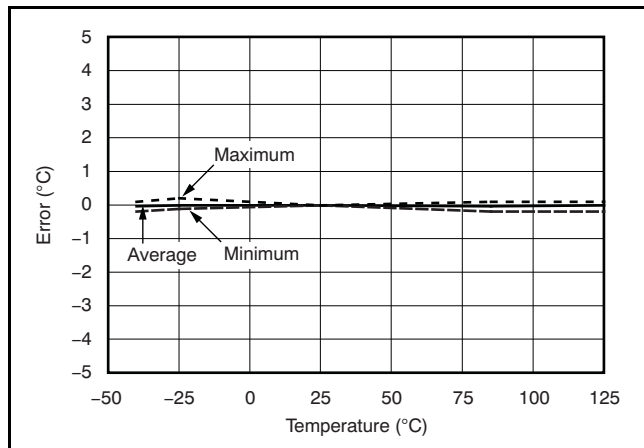

Figure 12. 5°C Hysteresis Error vs Temperature

Bypass capacitors should be used on the supplies as well as on the R_{SET} and analog out (V_{TEMP}) pins when in noisy environments, as shown in Figure 14. These capacitors reduce premature triggering of the comparator.

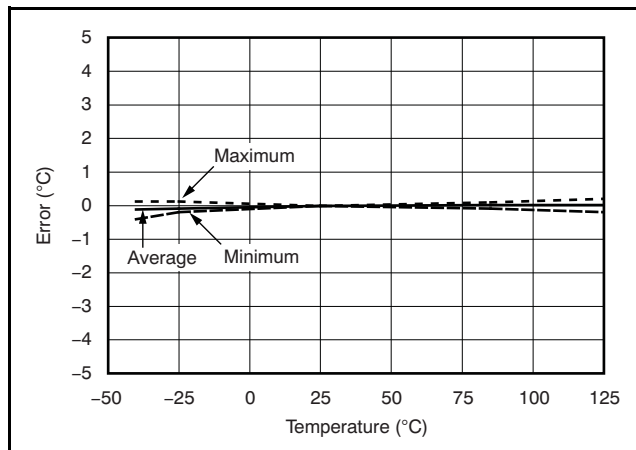

Figure 13. 10°C Hysteresis Error vs Temperature

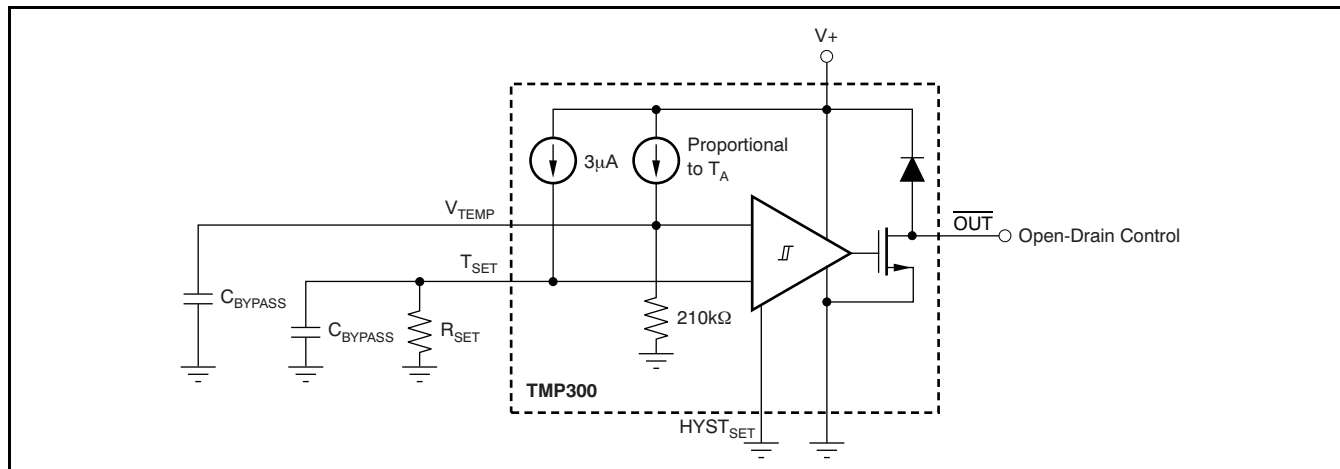

Figure 14. Bypass Capacitors Prevent Early Comparator Toggling Due to Circuit Board Noise

PACKAGING INFORMATION

Orderable Device	Status ⁽¹⁾	Package Type	Package Drawing	Pins	Package Qty	Eco Plan ⁽²⁾	Lead/Ball Finish	MSL Peak Temp ⁽³⁾
TMP300AIDBVR	PREVIEW	SOT-23	DBV	6	3000	TBD	Call TI	Call TI
TMP300AIDBVT	PREVIEW	SOT-23	DBV	6	250	TBD	Call TI	Call TI
TMP300AIDCKR	ACTIVE	SC70	DCK	6	3000	Green (RoHS & no Sb/Br)	CU NIPDAU	Level-1-260C-UNLIM
TMP300AIDCKRG4	ACTIVE	SC70	DCK	6	3000	Green (RoHS & no Sb/Br)	CU NIPDAU	Level-1-260C-UNLIM
TMP300AIDCKT	ACTIVE	SC70	DCK	6	250	Green (RoHS & no Sb/Br)	CU NIPDAU	Level-1-260C-UNLIM
TMP300AIDCKTG4	ACTIVE	SC70	DCK	6	250	Green (RoHS & no Sb/Br)	CU NIPDAU	Level-1-260C-UNLIM

⁽¹⁾ The marketing status values are defined as follows:

ACTIVE: Product device recommended for new designs.

LIFEBUY: TI has announced that the device will be discontinued, and a lifetime-buy period is in effect.

NRND: Not recommended for new designs. Device is in production to support existing customers, but TI does not recommend using this part in a new design.

PREVIEW: Device has been announced but is not in production. Samples may or may not be available.

OBSELETE: TI has discontinued the production of the device.

⁽²⁾ Eco Plan - The planned eco-friendly classification: Pb-Free (RoHS), Pb-Free (RoHS Exempt), or Green (RoHS & no Sb/Br) - please check <http://www.ti.com/productcontent> for the latest availability information and additional product content details.

TBD: The Pb-Free/Green conversion plan has not been defined.

Pb-Free (RoHS): TI's terms "Lead-Free" or "Pb-Free" mean semiconductor products that are compatible with the current RoHS requirements for all 6 substances, including the requirement that lead not exceed 0.1% by weight in homogeneous materials. Where designed to be soldered at high temperatures, TI Pb-Free products are suitable for use in specified lead-free processes.

Pb-Free (RoHS Exempt): This component has a RoHS exemption for either 1) lead-based flip-chip solder bumps used between the die and package, or 2) lead-based die adhesive used between the die and leadframe. The component is otherwise considered Pb-Free (RoHS compatible) as defined above.

Green (RoHS & no Sb/Br): TI defines "Green" to mean Pb-Free (RoHS compatible), and free of Bromine (Br) and Antimony (Sb) based flame retardants (Br or Sb do not exceed 0.1% by weight in homogeneous material)

⁽³⁾ MSL, Peak Temp. -- The Moisture Sensitivity Level rating according to the JEDEC industry standard classifications, and peak solder temperature.

Important Information and Disclaimer:The information provided on this page represents TI's knowledge and belief as of the date that it is provided. TI bases its knowledge and belief on information provided by third parties, and makes no representation or warranty as to the accuracy of such information. Efforts are underway to better integrate information from third parties. TI has taken and continues to take reasonable steps to provide representative and accurate information but may not have conducted destructive testing or chemical analysis on incoming materials and chemicals. TI and TI suppliers consider certain information to be proprietary, and thus CAS numbers and other limited information may not be available for release.

In no event shall TI's liability arising out of such information exceed the total purchase price of the TI part(s) at issue in this document sold by TI to Customer on an annual basis.

TAPE AND REEL INFORMATION



QUADRANT ASSIGNMENTS FOR PIN 1 ORIENTATION IN TAPE



*All dimensions are nominal

Device	Package Type	Package Drawing	Pins	SPQ	Reel Diameter (mm)	Reel Width W1 (mm)	A0 (mm)	B0 (mm)	K0 (mm)	P1 (mm)	W (mm)	Pin1 Quadrant
TMP300AIDCKR	SC70	DCK	6	3000	179.0	8.4	2.2	2.5	1.2	4.0	8.0	Q3
TMP300AIDCKT	SC70	DCK	6	250	179.0	8.4	2.2	2.5	1.2	4.0	8.0	Q3

TAPE AND REEL BOX DIMENSIONS



*All dimensions are nominal

Device	Package Type	Package Drawing	Pins	SPQ	Length (mm)	Width (mm)	Height (mm)
TMP300AIDCKR	SC70	DCK	6	3000	195.0	200.0	45.0
TMP300AIDCKT	SC70	DCK	6	250	220.0	205.0	50.0

DBV (R-PDSO-G6)

PLASTIC SMALL-OUTLINE PACKAGE



- NOTES:
- A. All linear dimensions are in millimeters.
 - B. This drawing is subject to change without notice.
 - C. Body dimensions do not include mold flash or protrusion. Mold flash and protrusion shall not exceed 0.15 per side.
 - D. Leads 1,2,3 may be wider than leads 4,5,6 for package orientation.
- $\triangle E$ Falls within JEDEC MO-178 Variation AB, except minimum lead width.

DCK (R-PDSO-G6)

PLASTIC SMALL-OUTLINE PACKAGE



- NOTES:
- A. All linear dimensions are in millimeters.
 - B. This drawing is subject to change without notice.
 - C. Body dimensions do not include mold flash or protrusion. Mold flash and protrusion shall not exceed 0.15 per side.
 - D. Falls within JEDEC MO-203 variation AB.

IMPORTANT NOTICE

Texas Instruments Incorporated and its subsidiaries (TI) reserve the right to make corrections, modifications, enhancements, improvements, and other changes to its products and services at any time and to discontinue any product or service without notice. Customers should obtain the latest relevant information before placing orders and should verify that such information is current and complete. All products are sold subject to TI's terms and conditions of sale supplied at the time of order acknowledgment.

TI warrants performance of its hardware products to the specifications applicable at the time of sale in accordance with TI's standard warranty. Testing and other quality control techniques are used to the extent TI deems necessary to support this warranty. Except where mandated by government requirements, testing of all parameters of each product is not necessarily performed.

TI assumes no liability for applications assistance or customer product design. Customers are responsible for their products and applications using TI components. To minimize the risks associated with customer products and applications, customers should provide adequate design and operating safeguards.

TI does not warrant or represent that any license, either express or implied, is granted under any TI patent right, copyright, mask work right, or other TI intellectual property right relating to any combination, machine, or process in which TI products or services are used. Information published by TI regarding third-party products or services does not constitute a license from TI to use such products or services or a warranty or endorsement thereof. Use of such information may require a license from a third party under the patents or other intellectual property of the third party, or a license from TI under the patents or other intellectual property of TI.

Reproduction of TI information in TI data books or data sheets is permissible only if reproduction is without alteration and is accompanied by all associated warranties, conditions, limitations, and notices. Reproduction of this information with alteration is an unfair and deceptive business practice. TI is not responsible or liable for such altered documentation. Information of third parties may be subject to additional restrictions.

Resale of TI products or services with statements different from or beyond the parameters stated by TI for that product or service voids all express and any implied warranties for the associated TI product or service and is an unfair and deceptive business practice. TI is not responsible or liable for any such statements.

TI products are not authorized for use in safety-critical applications (such as life support) where a failure of the TI product would reasonably be expected to cause severe personal injury or death, unless officers of the parties have executed an agreement specifically governing such use. Buyers represent that they have all necessary expertise in the safety and regulatory ramifications of their applications, and acknowledge and agree that they are solely responsible for all legal, regulatory and safety-related requirements concerning their products and any use of TI products in such safety-critical applications, notwithstanding any applications-related information or support that may be provided by TI. Further, Buyers must fully indemnify TI and its representatives against any damages arising out of the use of TI products in such safety-critical applications.

TI products are neither designed nor intended for use in military/aerospace applications or environments unless the TI products are specifically designated by TI as military-grade or "enhanced plastic." Only products designated by TI as military-grade meet military specifications. Buyers acknowledge and agree that any such use of TI products which TI has not designated as military-grade is solely at the Buyer's risk, and that they are solely responsible for compliance with all legal and regulatory requirements in connection with such use.

TI products are neither designed nor intended for use in automotive applications or environments unless the specific TI products are designated by TI as compliant with ISO/TS 16949 requirements. Buyers acknowledge and agree that, if they use any non-designated products in automotive applications, TI will not be responsible for any failure to meet such requirements.

Following are URLs where you can obtain information on other Texas Instruments products and application solutions:

Products

Amplifiers	amplifier.ti.com
Data Converters	dataconverter.ti.com
DSP	dsp.ti.com
Clocks and Timers	www.ti.com/clocks
Interface	interface.ti.com
Logic	logic.ti.com
Power Mgmt	power.ti.com
Microcontrollers	microcontroller.ti.com
RFID	www.ti-rfid.com
RF/IF and ZigBee® Solutions	www.ti.com/lprf

Applications

Audio	www.ti.com/audio
Automotive	www.ti.com/automotive
Broadband	www.ti.com/broadband
Digital Control	www.ti.com/digitalcontrol
Medical	www.ti.com/medical
Military	www.ti.com/military
Optical Networking	www.ti.com/opticalnetwork
Security	www.ti.com/security
Telephony	www.ti.com/telephony
Video & Imaging	www.ti.com/video
Wireless	www.ti.com/wireless

Mailing Address: Texas Instruments, Post Office Box 655303, Dallas, Texas 75265
Copyright © 2008, Texas Instruments Incorporated